

COMBY PLANTS RCT3

Compact Systems for pre-treatment of cesspool-interceptor septage

MACHINE DESCRIPTION

The septage acceptance unit is a system studied to receive and mechanically pre-treat effluents from cesspools with a single compact unit.

The sludges, discharged from tanker trucks, are filtrate to remove large particles, thus sand is settled and washed, finally grease and oily particles are floated and scraped from the sludge surface. The conditioned effluent is afterwards discharged into the biological wastewater treatment plant.

WORKING LOGIC FOR COMBY PLANTS RCT3

Tanker trucks get connected to the unit through a flex hose **DN.100** and clamped by a quick spherical connection. Solid large particle included in the waste are captured and removed by the inlet fine screw screen. The screw removes and compact the screenings before discharge. Along the conveying section is installed a washing system consisting of a set of nozzles where pressurised water is sprayed into the screenings themselves. The washing system allows to remove fecal matter from the screenings discharging a neat solid which can be landfilled without bothering of smells or leakages. At the discharge a built-in compactor is installed reducing the screenings volume by up to **50%**. Once screened the sludge enters the aerated sedimentation tank where sand deposits on the bottom of the tank, while organics are kept in suspension by the air injection. The coarse air bubbles allow to wash out the sand and allows the separation of sand having a reduced organic content.



The extraction screw removes and discharges the sand into the sand bin. The **RCT3** type is also equipped with a grease and oil skimmer. A travelling floating skimmer is installed in a side channel where grease are concentrate by the air pattern and segregate through a reverse Thomson-like baffle. The skimmer removes on a timer the floating parts and discharges them through a discharge pipe.

MAIN ADVANTAGES FOR COMBY PLANTS RCT3

- No leaks, smells or aerosols generated by the system.
- No drives in contact with the sludge.
- Compact design and small footprint.
- No concrete casting required.
- Low operation and maintenance costs.
- Low costs for installation and erection.
- Excellent screening performance with up to 52% solids capture ratio.

GENERAL DIMENSIONAL DATA FOR COMBY PLANTS RCT3

Here we provide some information about technical nature for this type of screens:

- Filtration with 6 mm perforated screen.
- Screenings removal and conveying to the discharge point with a single drive.
- Screenings volume reduction up to 50%.
- Sand removal up to 90% of sand having size 200 micron and bigger.
- Floating grease and oils reclaiming.
- Effective drainage of the screenings along the conveying section combined with a compaction section for more volume reduction and water removal.
- Screenings washing performed by the REMSPRAY integrated system using 3 independent washing cycles.

R.E.M. RCT3 septage receiving stations can be equipped with the following accessories:

- vertical discharge.
- bagging (single or endless bag type).
- heating and weather protection.
- centralized solenoid valves and piping.
- control cabinet.
- ATEX or UL NEMA 7 EX-proof version.

STANDARD DIMENSIONAL DATA FOR COMBY PLANTS RCT3

RCT3 MODELS	A - mm	B - mm	C - mm	Ø INLET	Ø OUTLET	FLOWRATES m ³ /h
RCT3/15	3700	2650	1070	DN100	DN200	50
RCT3/30	5200	2650	1070	DN100	DN200	100

n.b.: the manufacturer may modify some dimensions or sizes without prior information

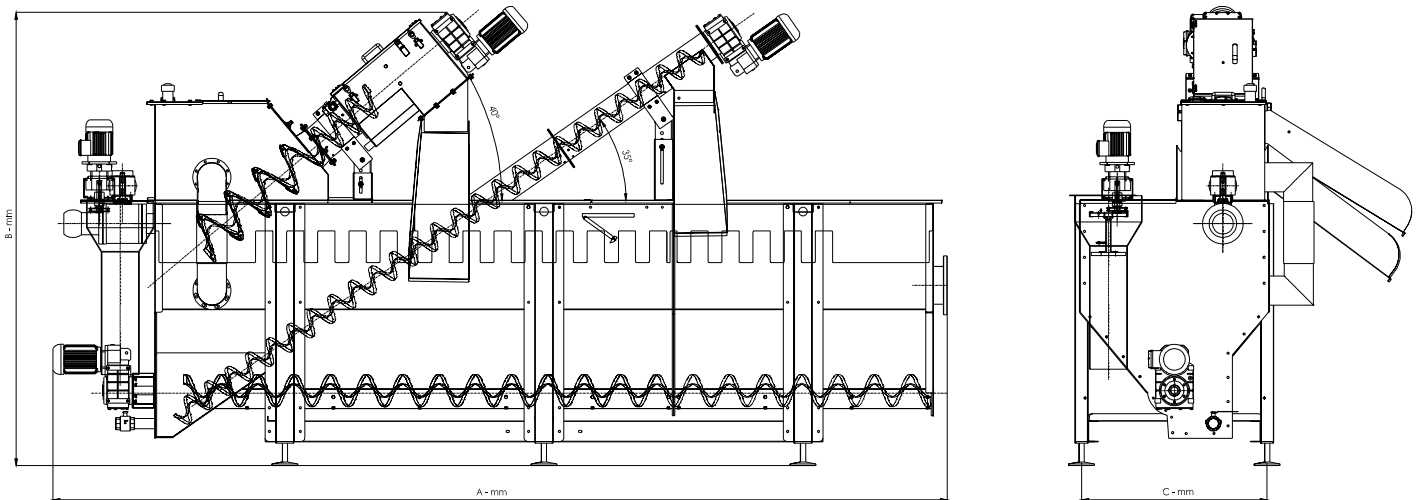

Materials of construction for fabricated parts:

*Stainless Steel AISI304 / *Stainless Steel AISI316

Materials of construction of spiral: *Stainless Steel AISI304 / *Stainless Steel AISI316 / *High resistance steel HRS

