

IN-CHANNEL SCREW SCREENS RSE

Screw Screens for Mechanical solids/liquids separation

MACHINE DESCRIPTION

R.E.M. range of screw screens for solids/liquid separation is a broad and vast selection where units for every application can be found. **RSE** Screw screens are multipurpose units capable to screen and convey the screenings.

WORKING LOGIC FOR SCREW SCREENS RSE

REM RSE screw screens are generally installed in municipal applications as they allow to have a single unit performing the whole process. **RSE** Screwscreens are made of the following sections:

- Screen
- Transport section
- Discharge
- Drive
- Support

Screw screens are successfully installed for the following applications:

- Municipal sewage
- Industrial effluent treatment
- Industrial process applications (i.e. vegetable screenings, entrails screenings, etc.).



MAIN FEATURES FOR SCREW SCREENS RSE

1. Screen frame available with perforated or wedge-wire screen aperture in various sizes.
2. The machine is self-cleaning, thanks to the brushes fitted on the screw conveyor.
3. The shaftless screw conveyor allows lifting of materials of different shapes and sizes, which are, however, difficult to transport.
4. The wide range available makes it possible to choose the right version to suit the application requirements.
5. The stainless steel structure along with brushes made of plastic material enable the use of the machine for handling acids, basic products and foodstuffs.
6. Entire operation of the machine is handled by the drive units.
7. Installation is easy and fast.
8. Maintenance is very simple and time saving.

GENERAL DIMENSIONAL DATA FOR SCREW SCREENS RSE

Here we provide some information about technical nature for this type of screens:

- Filtration with screens sizes ranges from 250 microns (wedge-wire) to 12 mm (perforated).
- Models suitable for channels from 300 to 900 mm wide.
- Screenings removal and conveying to the discharge point with a single drive.
- Screenings washing performed by the REMSPRAY integrated system using 3 independent washing cycles.

The main advantages are:

- reduced installation costs.
- high solids capture removal (52% tested).
- nuisance and leachate reduction.
- reduced handling and disposal costs.

R.E.M. RSE screw screens can be equipped with the following accessories:

- vertical discharge.
- bagging (single or endless bag type)
- heating and weather protection.
- centralized solenoid valves and piping.
- control cabinet.
- ATEX or UL NEMA 7 EX-proof version.

STANDARD DIMENSIONAL DATA FOR SCREW SCREENS RSE

Here we provide some information about technical nature for this type of screens.

FLOWRATES m³/h

RSE MODELS	PERFORATED PLATE SCREEN - mm				RSE MODELS	WEDGE WIRE SCREEN - mm			
	3	4	5	6		0.25	0.5	1	2
RSE200	75.6	97.2	115.2	129.6	RSE200	28.8	57.6	86.4	108
RSE300	115.2	151.2	169.2	198	RSE300	54	90	126	151.2
RSE400	198	234	270	306	RSE400	79.2	144	216	252
RSE500	324	378	414	468	RSE500	144	234	342	396
RSE600	432	504	576	684	RSE600	180	306	468	540
RSE700	756	900	972	1116	RSE700	324	540	756	900



Materials of construction for fabricated parts:

*Stainless Steel AISI304 / *Stainless Steel AISI316

Materials of construction of spiral:

*Stainless Steel AISI304 / *Stainless Steel AISI316 / *High resistance steel HRS

RSE MODELS	Ø - mm	A - mm	B - mm	C - mm	MIN. D - mm	MAX. D - mm
RSE200	219	4000	1300	596	270	400
RSE300	219	4178	1383	607	480	600
RSE400	219	4600	1538	686	480	600
RSE500	219	5006	1538	895	580	700
RSE600	323	4061	1416	870	690	800
RSE700	323	5821	1416	1308	690	800

INCLINATION: min. 30° - max. 45°

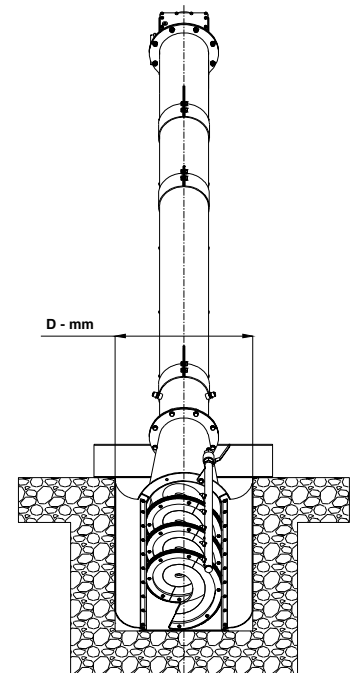
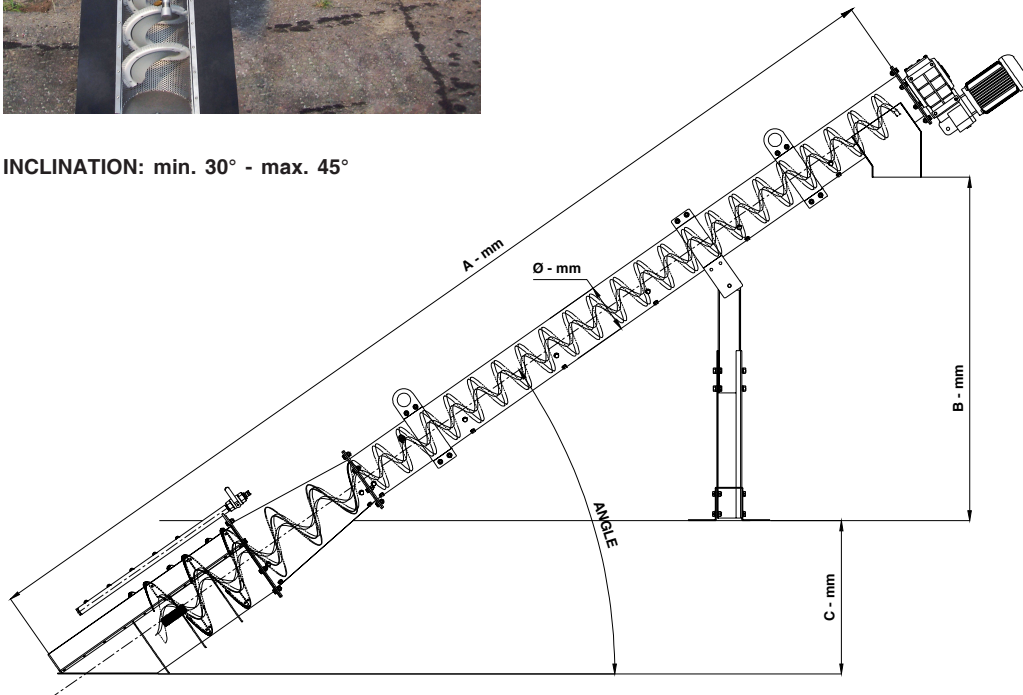

n.b.: the manufacturer may modify some dimensions or sizes without prior information