

MINISCREEN MINI-RSE

Small Screw Screens for Mechanical solids/liquids separation

MACHINE DESCRIPTION

R.E.M. range of screw screens for solids/liquid separation is a broad and vast selection where units for every application can be found. **MINI-RSE** Screw screens are multipurpose units capable to screen and convey the screenings.

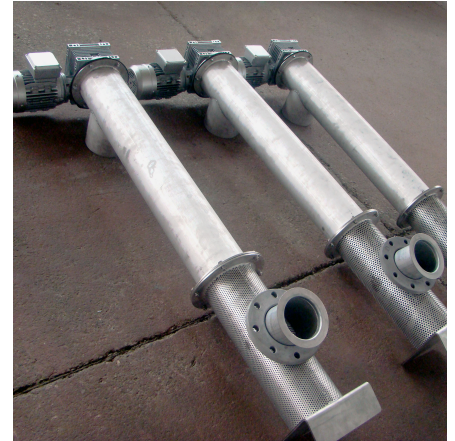
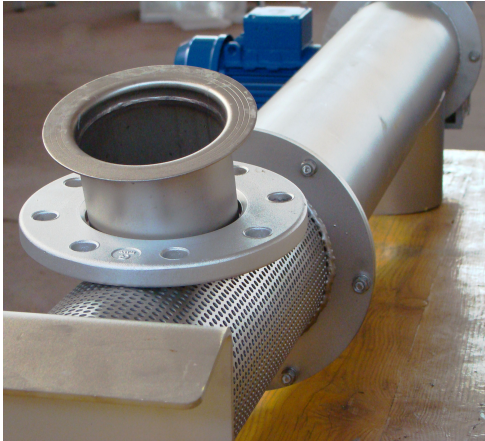

WORKING LOGIC FOR SMALL SCREW SCREENS MINI-RSE

REM MINI-RSE screw screens are generally installed in municipal applications as they allow to have a single unit performing the whole process. **MINI-RSE** Screens are made of the following sections:

- Screen.
- Transport section.
- Discharge.
- Drive.

Screw screens are successfully installed for the following applications:

- Municipal sewage.
- Pumping stations.

GENERAL DIMENSIONAL DATA FOR SMALL SCREW SCREENS MINI-RSE

Here we provide some information about technical nature for this type of screens:

- Filtration with screens sizes ranges from 3 to 6 mm (perforated).
- Models suitable for incoming piping from DN150 to DN200 mm.
- Screenings removal and conveying to the discharge point with a single drive.

R.E.M. **MINI-RSE** screw screens can be equipped with the following accessories:

- control cabinet.
- ATEX or UL NEMA 7 EX-proof version.

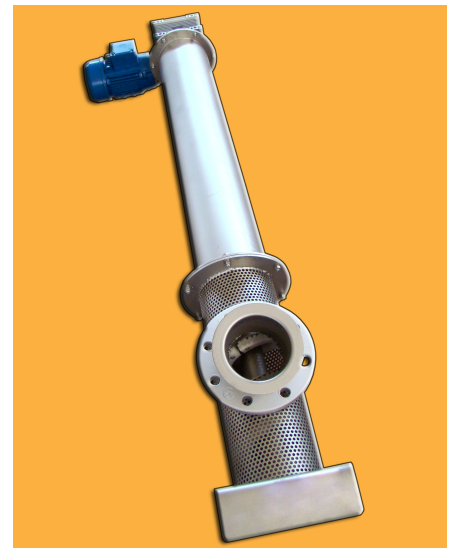

MAIN FEATURES FOR SMALL SCREW SCREENS MINI-RSE

1. Screen frame available with perforated screen aperture in various sizes.
2. The machine is self-cleaning, thanks to the brushes fitted on the screw conveyor.
3. The shaftless screw conveyor allows lifting of materials of different shapes and sizes, which are, however, difficult to transport.
4. The range available makes it possible to choose the right version to suit the application requirements.
5. The stainless steel structure along with brushes made of plastic material enable the use of the machine for handling acids, basic products and foodstuffs.
6. Entire operation of the machine is handled by the drive units.
7. Installation is easy and fast.
8. Maintenance is very simple and time saving.

The main advantages are:

- reduced installation, handling and disposal costs.
- high solids capture removal (52% tested).
- nuisance and leachate reduction.

STANDARD DIMENSIONAL DATA FOR SMALL SCREW SCREENS MINI-RSE

MINIRSE MODELS	Ø - mm	A - mm	FLOWRATE - m3/h		
			Perforation Ø3 mm	Perforation Ø5 mm	Perforation Ø6 mm
MINIRSE/168	168	1450	13	20	25
MINIRSE/219	219	1450	17	26	32

INCLINATION: 20°

IMPORTANT THESE MINISCREENS ARE AVAILABLE ALSO FOR PIPELINE INSTALLATION.

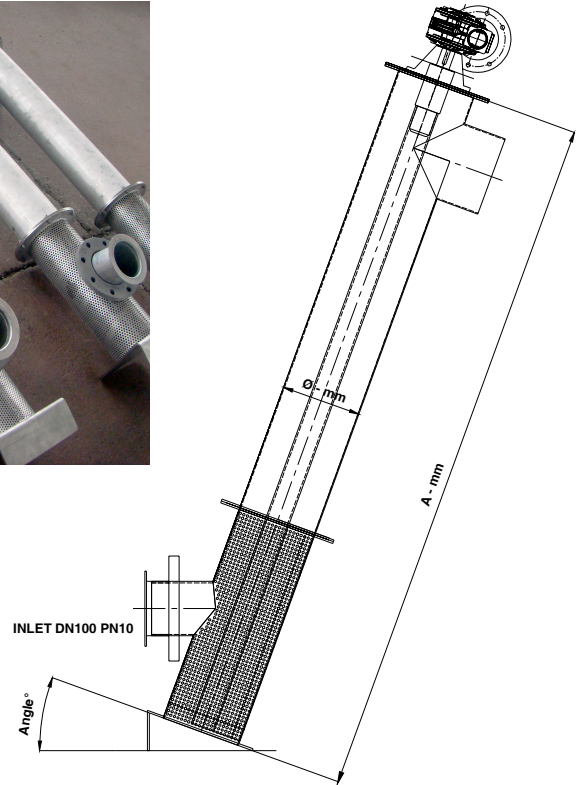
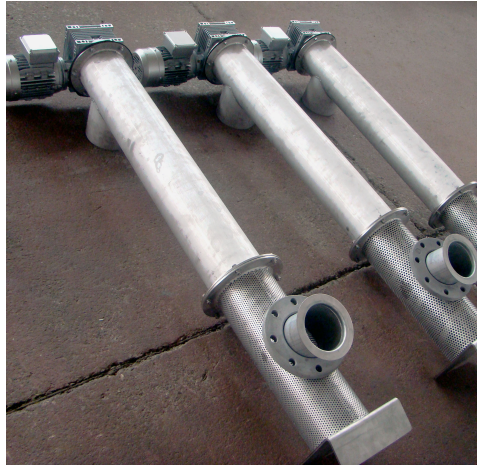

Materials of construction for fabricated parts:
Stainless Steel AISI304 / Stainless Steel AISI316

Materials of construction of spiral:
*Stainless Steel AISI304 / *Stainless Steel AISI316 / *High resistance steel HRS

.b.: the manufacturer may modify some dimensions or sizes without prior information